

Automated Copying of Schematics and PCB Layouts

John C. Luciani Jr.

March 16, 2008

Contents

Overview

Creating a Design

sch-matrix

pcb-matrix

Creating Configuration Files

Example – Electronic Load

Load Schematic

Load PCB

PCB Configuration File...

Schematic Configuration...

References

Change Log

License

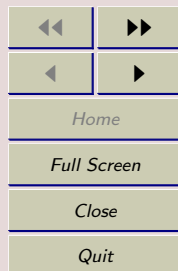

1 Overview

The scripts `pcb-matrix` and `sch-matrix` replicate PCB and schematic structures by copying an input file to an output file multiple times incrementing the (x,y) position of each copy. The copied structures are arranged in a matrix as specified in a configuration file.

N.B. These scripts may not work for all layouts. I wrote sufficient code to copy the schematic and PCB elements for one of my designs not for all possible designs.

Conventions

<code><parameter></code>	Replace with the value of <i>parameter</i>
<code>verbatim text</code>	Verbatim text when associated with a command or contents of a file.
<code>sch-matrix</code>	The current version of the schematic matrix program.
<code>pcb-matrix</code>	The current version of the PCB matrix program.
<code>sch-matrix_<version></code>	Version <i><version></i> of the schematic matrix program.
<code>pcb-matrix_<version></code>	Version <i><version></i> of the PCB matrix program.

Contents

Overview

Creating a Design

`sch-matrix`

`pcb-matrix`

Creating Configuration Files

Example – Electronic Load

Load Schematic

Load PCB

PCB Configuration File...

Schematic Configuration...

References

Change Log

License

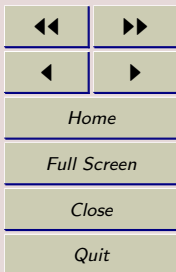

2 Creating a Design

To create a design:

create an input schematic
create an input PCB

Create a schematic that contains the structure to be replicated.
run `gschpcb` on the input schematic and create a PCB layout (which will be the input PCB layout).

add the marker line to the input PCB
create configuration files
create an output schematic
create an output PCB

using your favorite editor (`emacs`) add the marker line to the input PCB.
create configuration files for `sch-matrix` and `pcb-matrix`.
run `sch-matrix`
run `pcb-matrix`

If all of the reference designators are assigned in the input schematic and that schematic is used to create the input PCB file then all of the reference designators in the output schematics and PCB files will be in-sync. `sch-matrix` and `pcb-matrix` use the same algorithm to update reference designators.

[Contents](#)

[Overview](#)

[Creating a Design](#)

[sch-matrix](#)

[pcb-matrix](#)

[Creating Configuration Files](#)

[Example – Electronic Load](#)

[Load Schematic](#)

[Load PCB](#)

[PCB Configuration File...](#)

[Schematic Configuration...](#)

[References](#)

[Change Log](#)

[License](#)

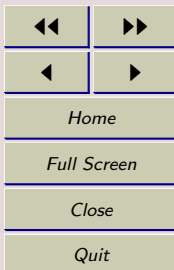

3 sch-matrix

Usage

`sch-matrix_0` (*configuration filename*)

Description

The `sch-matrix` script creates a new layout by coping each `component`, `text` value, `net`, `line` and `circle` to an output file multiple times. Each structure is positioned as defined by the parameters in the configuration file. For each `component` the reference designator is updated to maintain unique reference designators in the output file.

3.1 Creating the Schematic

Schematics are created in the usual manner using `gschem`. Prior to running `sch-matrix` all of the reference designators (refdes's) must be assigned. `sch-matrix` dies if the refdes does not match an alphabetic string followed by integer (*which is the regular expression `[A-Za-z]+\d+`*).

3.2 Connecting the Replicated Schematics

The replicated schematics can be connected by naming nets or by placing nets so that they will physically connect after replication. Naming the nets produces less clutter on the schematic but does not show connectivity. Using continuous nets shows connectivity but can be messy when there are many nets or nets in many directions (such as when groups of components are arranged in a matrix).

If the groups are all in a row (or all in a column) then a continuous horizontal (or vertical) net can be placed. By choosing the appropriate length for the net and the proper `xoffset` and `yoffset` a single continuous net will be created in the output file. For a matrix a combination of net names and continuous nets may be best.

3.3 Adding Circuitry to the Output Schematic

Usually additional circuitry will need to be added to the output schematic to complete a design. However, everytime `sch-matrix` is run the output schematic is overwritten. If you embed the output schematic in your design using a hierarchical block then this problem is eliminated. Since connections to the block are by net names no changes are required when `sch-matrix` is re-run.

Contents

Overview

Creating a Design

sch-matrix

pcb-matrix

Creating Configuration Files

Example – Electronic Load

Load Schematic

Load PCB

PCB Configuration File...

Schematic Configuration...

References

Change Log

License

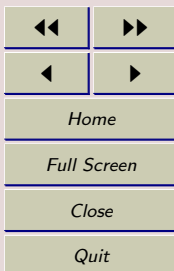

4 pcb-matrix

Usage

`pcb-matrix_0` (*configuration filename*)

Description

The `pcb-matrix` script creates a new layout by coping each `Element`, `Polygon`, `Via` and `Line` from an input file to an output file multiple times. Each layout, from the input file, is positioned as defined by the parameters in the configuration file. For each `Element` the reference designator is updated to maintain unique reference designators in the output file.

In a PCB file there is a variety of data prior to the start of the layout (*e.g.* user interface settings, character symbols) . It does not seem desirable to replicate all of that data. Rather than try to guess where the layout starts the `pcb-matrix` program requires a marker line in the input file to indicate the start of the layout. The marker line is a line containing only the string `#####_PCB_#####` which is a legal PCB comment line. This marker line has to be reinserted each time you save the PCB layout.

The start of the layout seems to reside after all of the symbol declarations and before the vias. `pcb-matrix` will copy all of the lines prior to the marker to the output file verbatim. After the marker line is read the remaining lines will be output $r \cdot c$ times in a matrix (where r is the number of rows and c is the number of columns specified in the configuration file).

4.1 Adding Circuitry to the Output PCB Layout

Usually additionaly circuitry will need to be added to the output PCB layout to complet a design. However, everytime `pcb-matrix` is run the output layout is overwritten.

If you embed the output layout in your design using the `load layout data to paste-buffer` command then you can reload it if changes need to be made. Since the output layout is self-contained only the peripheral connections will need to updated. To reload an output layout into your design:

1. Delete the peripheral connections that connect the output layout to your design.
2. Delete the output layout.
3. Use `load layout data to paste-buffer` to add the output layout
4. Add the peripheral connections.



Home

Full Screen

Close

Quit

Contents

Overview

Creating a Design

`sch-matrix`

`pcb-matrix`

Creating Configuration Files

Example – Electronic Load

Load Schematic

Load PCB

PCB Configuration File...

Schematic Configuration...

References

Change Log

License

5 Creating Configuration Files

The configuration file format is the same for `sch-matrix` and `pcb-matrix`. Each file can contain comments, empty lines and lines that set parameters. Comments start with a `#` and proceed to the end of the current line. Comments and empty lines are ignored by the parser. The lines that set parameters are in the format:

`<parameter name> | <parameter value>`

where `<parameter name>` is one of the names listed in [Table 1](#).

Name	Type of Value	Description
<code>x0</code>	Integer	the x coordinate (in mils) of the starting position in the output file
<code>y0</code>	Integer	the y coordinate (in mils) of the starting position in the output file
<code>xoffset</code>	Integer	the center-to-center column spacing (in mils)
<code>yoffset</code>	Integer	the center-to-center row spacing (in mils)
<code>last_col</code>	Ordinal	the ordinal of the last column (column ordinals start at 0)
<code>last_row</code>	Ordinal	the ordinal of the last row (row ordinals start at 0)
<code>input_filename</code>	String	the name of the file containing the structure that will be replicated
<code>output_filename</code>	String	the name of the file that contains the replicated structures

Table 1: Configuration File Parameters

[Contents](#)

[Overview](#)

[Creating a Design](#)

[sch-matrix](#)

[pcb-matrix](#)

[Creating Configuration Files](#)

[Example – Electronic Load](#)

[Load Schematic](#)

[Load PCB](#)

[PCB Configuration File...](#)

[Schematic Configuration...](#)

[References](#)

[Change Log](#)

[License](#)

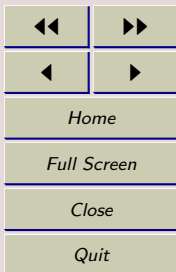

6 Example – Electronic Load

Occasionally a circuit design consists of a group of elements, a cell, that needs to be replicated multiple times. One example is an electronic load. An electronic load is a circuit that sinks current and is an essential instrument in power supply test.

Typically an electronic load consists of multiple load-cell circuits in parallel. Creating a load using multiple cells increases the total current sinking capability of the load. A schematic of a simplified load-cell circuit is shown in [Figure 1](#). The circuit consists of an op-amp, an N-channel MOSFET and current sensing resistor.

[Contents](#)

[Overview](#)

[Creating a Design](#)

[sch-matrix](#)

[pcb-matrix](#)

[Creating Configuration Files](#)

[Example – Electronic Load](#)

[Load Schematic](#)

[Load PCB](#)

[PCB Configuration File...](#)

[Schematic Configuration...](#)

[References](#)

[Change Log](#)

[License](#)

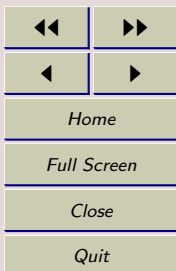

7 Load Schematic

When creating the load-cell schematic the nets that are to have cell-to-cell connections need to have sufficient length so that they overlap after replication. The ground net and the net from the drain of Q1 (Figure 1) are long enough so that an `xoffset` value of 3200 in the configuration will overlap the nets in the output file.

Prior to running `sch-matrix` all of the reference designators need to be assigned. `sch-matrix` will uniquely number all of the components in the output file based upon the assigned values in the input file.

The configuration file for `sch-matrix` is shown in Listing 2. Lines 13 and 14 define the cell spacing for rows and columns respectively. The values on lines 15 and 16 define a 1x4 matrix.

The output schematic shown in Figure 2 is the result of running `sch-matrix` using the configuration file in Listing 2. Notice that the horizontal nets have been connected and the reference designators of the copied cells have been uniquely assigned.

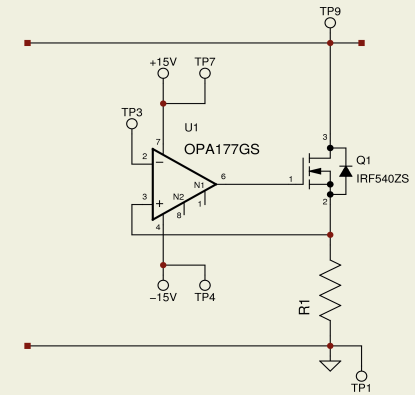

Figure 1: Load-cell Schematic

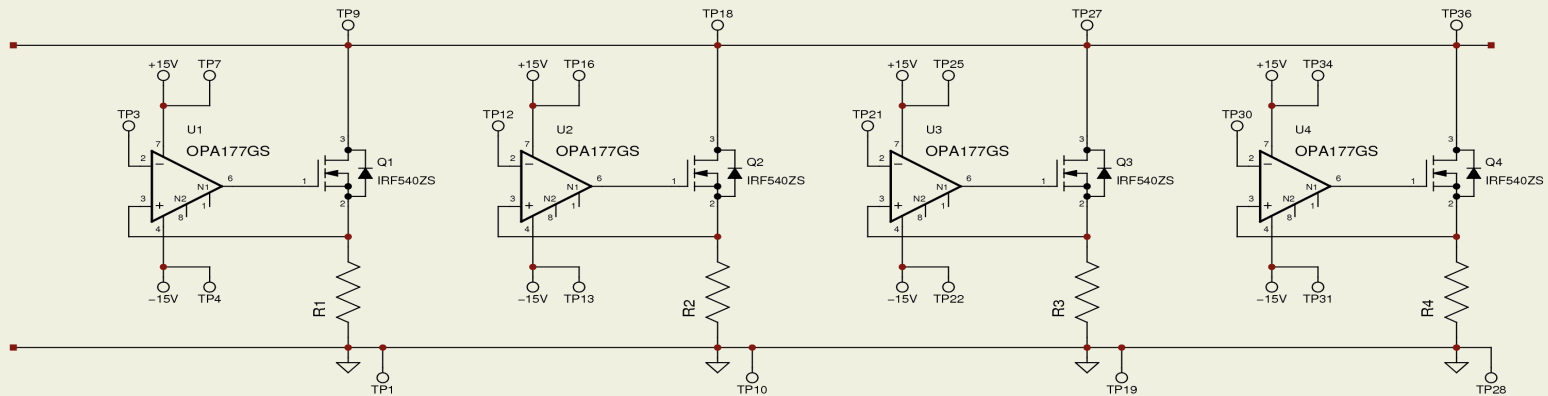

Figure 2: Load Schematic

Contents

Overview

Creating a Design

`sch-matrix`

`pcb-matrix`

Creating Configuration Files

Example – Electronic Load

Load Schematic

Load PCB

PCB Configuration File...

Schematic Configuration...

References

Change Log

License

◀◀	▶▶
◀	▶
Home	
Full Screen	
Close	
Quit	

8 Load PCB

After creating the schematic for the load-cell run `gsch2pcb` and create a layout for a single load-cell. An example load-cell layout is shown in [Figure 3](#).

In the load-cell layout the two high current traces are running parallel on the component side of the board along the top of the cell. The op-amp power and positive-input traces are running parallel on the solder side of the board at the bottom of the cell. All of the parallel traces are ≈ 950 mils long. Setting an `xoffset` of 900 mils will create an overlap between the cells in the output file.

Running `pcb-matrix` with the configuration file in [Listing 1](#) produces the layout in [Figure 4](#).

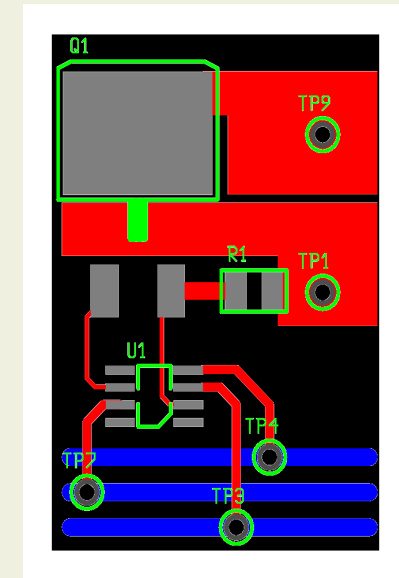

Figure 3: Load-cell PCB

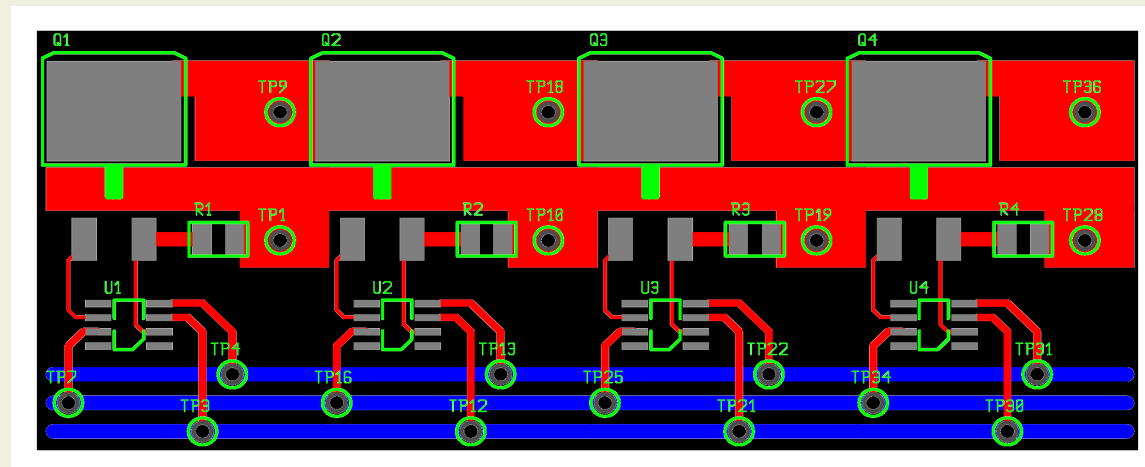

Figure 4: Load PCB

Contents

Overview

Creating a Design

sch-matrix

pcb-matrix

Creating Configuration Files

Example – Electronic Load

Load Schematic

Load PCB

PCB Configuration File...

Schematic Configuration...

References

Change Log

License

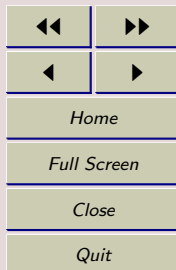

9 PCB Configuration File Example

Listing 1: Configuration File for the Electronic Load PCB

```
1 # x0          the x coordinate of the starting position in the output file
2 # y0          the y coordinate of the starting position in the output file
3 # xoffset     the column spacing
4 # yoffset     the row spacing
5 # last_col    the ordinal of the last column (column ordinals start at 0)
6 # last_row    the ordinal of the last row (row ordinals start at 0)
7 # input_filename the name of the file containing the PCB layout
8 #            that will be replicated
9 # output_filename the name of the file that contains the PCB matrix
10
11 x0          | 500
12 y0          | 100
13 xoffset     | 900
14 yoffset     | 0
15 last_col    | 3
16 last_row    | 0
17 input_filename | load-cell.pcb
18 output_filename | load.pcb
```

[Contents](#)

[Overview](#)

[Creating a Design](#)

[sch-matrix](#)

[pcb-matrix](#)

[Creating Configuration Files](#)

[Example – Electronic Load](#)

[Load Schematic](#)

[Load PCB](#)

[PCB Configuration File...](#)

[Schematic Configuration...](#)

[References](#)

[Change Log](#)

[License](#)



Home

Full Screen

Close

Quit

10 Schematic Configuration File Example

Listing 2: Configuration File for the Electronic Load Schematic

```
1 # x0          the x coordinate of the starting position in the output file
2 # y0          the y coordinate of the starting position in the output file
3 # xoffset     the column spacing
4 # yoffset     the row spacing
5 # last_col    the ordinal of the last column (column ordinals start at 0)
6 # last_row    the ordinal of the last row (row ordinals start at 0)
7 # input_filename the name of the file containing the schematic
8 #            that will be replicated
9 # output_filename the name of the file that contains the schematic matrix
10
11 x0          | 500
12 y0          | 100
13 xoffset     | 3200
14 yoffset     | 0
15 last_col    | 3
16 last_row    | 0
17 input_filename | load-cell.sch
18 output_filename | load.sch
```

[Contents](#)

[Overview](#)

[Creating a Design](#)

[sch-matrix](#)

[pcb-matrix](#)

[Creating Configuration Files](#)

[Example – Electronic Load](#)

[Load Schematic](#)

[Load PCB](#)

[PCB Configuration File...](#)

[Schematic Configuration...](#)

[References](#)

[Change Log](#)

[License](#)



Home

Full Screen

Close

Quit

References

- Eaton, H., & Nau, T. (2002). Pcb [Computer software and manual]. (Retrieved February 7, 2007 from <http://pcb.sourceforge.net/pcb-cvs/pcb.html>)
- Hvezda, A. (2003, Dec). gEDA/gaf File Format Document [Computer software and manual]. (Retrieved May 10, 2005 from <http://www.geda.seul.org/docs/current/fileformats/index.html>)

Contents

Overview

Creating a Design

sch-matrix

pcb-matrix

Creating Configuration Files

Example – Electronic Load

Load Schematic

Load PCB

PCB Configuration File...

Schematic Configuration...

References

Change Log

License

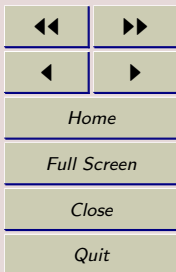

11 Change Log

pcb-matrix_0 Initial Release
sch-matrix_0 Initial Release

Contents

Overview

Creating a Design

sch-matrix

pcb-matrix

Creating Configuration Files

Example – Electronic Load

Load Schematic

Load PCB

PCB Configuration File...

Schematic Configuration...

References

Change Log

License

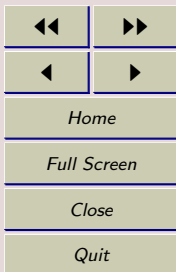

12 License

No-Fee License Version 0.2

Intent

The intent of this license is to allow for distribution of this documentation without fee. Usage of this documentation, other than distribution, is unrestricted.

License

Permission is granted to make and distribute verbatim copies of this document provided that (1) no fee is charged and (2) the original copyright notice and this license document are preserved on all copies.

Permission is granted to make and distribute modified versions of this document under the conditions for verbatim copying, provided that the entire resulting derived work is distributed under the terms of a license identical to this one.

This documentation is provided by the author **“AS IS”** and any express or implied warranties, including, but not limited to, the implied warranties of merchantability and fitness for a particular purpose are disclaimed. In no event shall the author be liable for any direct, indirect, incidental, special, exemplary, or consequential damages (including, but not limited to, procurement of substitute goods or services; loss of use, data, or profits; or business interruption) however caused and on any theory of liability, whether in contract, strict liability, or tort (including negligence or otherwise) arising in any way out of the use of this software, even if advised of the possibility of such damage.

[Contents](#)

[Overview](#)

[Creating a Design](#)

[sch-matrix](#)

[pcb-matrix](#)

[Creating Configuration Files](#)

[Example – Electronic Load](#)

[Load Schematic](#)

[Load PCB](#)

[PCB Configuration File...](#)

[Schematic Configuration...](#)

[References](#)

[Change Log](#)

[License](#)



Home

Full Screen

Close

Quit